

THE KWIKPRINT MANUFACTURING Co. INC.
KWIKPRINT INSTRUCTIONS
AND
SECRETS TO GOOD HOT-STAMPING

CONGRATULATIONS, you are now the proud owner of a Kwikprint. The worlds most versatile Hot Stamping Machine. You are about to add new profit potential to your business through the power of personalization.

Over the years, "KWIKPRINT" has been called upon to imprint such items as: ribbons, pencils, matchbooks, napkins, stationery, envelopes, business cards, key rings, clipboards, trophy plaques, luggage tags, golf bag tags, dash plates, lighters, name badges, book covers, daily planners, portfolio, ring binders, catalogs, photographs, photo albums, money folds, wallets, buttons, brief cases magnet material, motorcycle wind screens, identification plates, leather belts, labels, molded plastic products and much more.

The following instructions will give you the general information you will need to operate your Kwikprint machine. Always remember the 3 factors of hot stamping are; HEAT, PRESSURE, and DWELL TIME. These are very important factors that allow you to achieve perfect imprinting every time with your Kwikprint machine.

The Heat

Plug your machine into an electrical outlet then turn the heat control on starting with #8 setting. Allow the machine to heat-up for approx. 15 minutes, or until the proper heat desired is reached for the material you wish to imprint.

You may leave your Kwikprint machine on all day. However, we advise YOU to caution other employees or persons around the machine that the type holder is HOT. The glow light inside your Heat Control unit will indicate that your machine is on and heating. When the heat stabilizes, the glow light will go off and on, to indicate the heat is holding at the temperature desired. Please consult the information sheet for any questions or adjustments of the Heat Control.

The printing temperature will depend on the material being imprinted and the amount of area you wish to cover. Paper products usually require 225 - 275 degrees, the release temperature of the foils also vary depending on the type of foil you are using. Plastic products usually require a higher heat range, 275 - 350 degrees again, depending upon the type of plastic (polyethylene, polystyrene abs, polypropylene or Plexiglas, etc.)

If you know the material by name, we can help you select the correct foil. We will be able to better assist you in selecting the correct foils, if we have a sample of the material you are imprinting.

The Pressure

The Pressure needed to make a perfect imprint is actually light, with the exception of hard plastics such as, Plexiglas, engraving stock, etc. Depending on the amount of coverage being imprinted, the Pressure may vary, for example a long single line of type on a ring binder will require more pressure than imprinting a short name. When imprinting plastics, you will need more pressure to insure that the foil will cover evenly and be slightly embedded into the material. The pressure required for imprinting softer material, such as vinyl will be nothing more than a quick "kiss" impression.

Getting the right amount of pressure is a learned "touch" or "feel". A little practice on some scrap material will enable you to perfect your touch. Combine this touch with your knowledge of the material to be imprinted and you will have a beautiful imprint every time.

The Dwell Time

The Dwell time or "Hold-Down" time is a very important factor and the most abused in hot-stamping. Many people feel they need to apply more dwell time than really necessary. Too long of a Dwell time will "bleed" or melt the foil giving a blurred image, instead of a clean, crisp imprint.

The Dwell Time will depend upon the material being imprinted and the area of coverage and the temperature. When using type or dies of small or medium size, one should use a "quick" dwell time (1-2) seconds. A single line name in almost any size type will only take a second or two to release on soft material such as leather, vinyl and some paper stock. We recommend that you always practice on the material first, to test your dwell time, heat setting and the amount of pressure to use.

Dwell time, heat and pressure are all interrelated. Dwell time that is too short will give you a partial imprint, too long will give you a "bleeding" or smearing effect. Heat that is too high will cause the same bleeding effect. Heat that is too low will also give a partial imprint.

The bleeding effect may also be caused by the foil. Some foils may have a greater amount of pigment or powder. The over-print can usually be wiped off in this case. It is important to choose the correct foil for your application. Call us if you are not sure.

Type Setting

While your Typeholder is heating, set up your copy. Note, all type pieces have “notches” or grooves on the bottom surface of each piece.

For most stamping, you will set your type or die with the notches up reading left to right. This is generally recommended for doing the upper two-thirds of an area. When you are imprinting a company name or a title on a portfolio, set your type into the Typeholder with the notches up.

If you are going to imprint a single line name on the lower right-hand corner of a portfolio, turn the portfolio around to stamp the bottom area. The type will be put into the Typeholder right-side up notches down reading right to left. This is generally recommended for doing the lower third area of the material to be imprinted. We suggest you always test stamp on paper to check your spelling and the alignment of the type.

The Typeholder is self-centering to the centerline of the lineboard . However, if you have a "two-way platform, your type will not always be centered to the centerline. Slide the material to be imprinted onto the platform, check that the line of type is positioned properly. You are now ready to stamp. Place the foil over the desired area and pull the handle down to make your impression. Release the handle and remove the foil.

Type Styles

Our Service Type Catalog will show you all the type styles we have to offer in stock. This is usually a personal decision and /or depending on how much room you have to imprint. If a style is needed that is not in our catalog, please call us and we will order it.

Loading The Typeholder

After "Your Name" is set up in the aluminum type stick, open the jaws of the Typeholder a little wider than the line of type. Use the Tilt Lock Handle to lock your Typeholder in the up position. Turn the ball knobs to open the jaws of the Typeholder and slide the type between the jaws. After making sure all the pieces of type are firmly resting against the back of the Typeholder by tapping the lines slightly, tighten the jaws against the type. DO NOT OVER TIGHTEN. The type will expand with heat.

When using the Multi-line" Typeholder to imprint more than one line at one time, you will need the Brass Type Support to secure the type from the top. The "Multi-line" feature of the Typeholder will require more set-up time because of the series of screws on either side of the Typeholder jaws. This feature is optional.

To imprint stationery with your name and address, set your type exactly like you want it to look. With the notches up, set the name line, address line, and city / state line in that order.

Place the name line into the Typeholder, use a spacer bar (lead bar used for spacing lines of type), which we supply in pre-cut lengths or lengths you cut to size. Place the spacer on top of the first line, then set the address line into the Typeholder.

If the address is smaller than the first line, you will need to use some "blank" spacers to even out each side to make them the same length as your first line (name line). Spacers are supplied with each FONT of Service Type.

Place a spacer bar on top of the second line and add the city, state, & zip code line. Again use blank spacers to even up each line. Finally place two or more additional spacer bars on top of the last line. To insure all of the lines are secured from the top tighten the "Type Support" thumb screw.

DO NOT LOWER YOUR TYPEHOLDER UNTIL YOU CHECK EACH LINE FOR TIGHTNESS,

If there is play in any line use a thin spacer to secure that line. If you have the "Multi-line" feature on your Typeholder, use the screw that lines up with that line to make sure the type is resting firmly against the back of the Typeholder

After all checks are made, tilt your Typeholder in the down position and you are ready to stamp. Again, remember to test stamp on a sample material to check spelling and clarity of imprint. Sometimes you will find a piece of type that is used more than others or a damaged piece. If so, you will need to replace it carefully, so not to disturb the other type.

Placing Your Work In Position

Using the "Right Angle" platform gauges whenever possible is the best way to position your work. The use of our cardboard gauges will be helpful for odd shaped or positioned products. The size and location of your imprint and the size of the material being imprinted, will determine the type of gauge you will use.

The Act Of Hot-Stamping

If you are not using the Automatic Rollfeed, take a roll of foil with the bright side up and place it over the items impression area. Pull the power lever handle down to bring the type or die down on the foil with a smooth stroke. Remember to use the right combination of Heat, Pressure and Dwell as discussed earlier. Again, you always need to consider how long of a line you are imprinting, type of material to be imprinted and type of foil used.

If you are stamping leather, you can make a blank impression first (without the foil). Next, being careful not to move the item, restamp the leather product with the foil. **DO NOT DO THIS ON VINYL OR OTHER MATERIAL.**

After stamping any item, return the handle to the up position and remove the foil from the impression. There is no drying time for foil, if there is any bleeding of foil, you may wipe off the excess with a clean soft cloth. If the foil has transferred properly, you will have a clear, sharp quality imprint on the material. If the imprint is not clear, do not move the item, you may be able to strike over the first imprint again. By adjusting for more pressure or dwell, come down on the material again. After you have gained necessary experience and confidence, you will know exactly how much pressure and dwell time to use on any material.

To better help you make the best quality imprint, call us prior to imprinting. We will assist you in selecting the correct foil, temperature and/or dwell time. You may also send us samples of any material you wish to stamp. Our service department will send your material back with our recommendations.

Custom Dies

We can supply you with "Custom Made" Hot-Stamping dies, for logos, special titles, special events, etc. We require camera ready artwork for logos or we can type-set what you need using type styles that are available. The normal lead time is 5 working days, with RUSH SERVICE at an additional charge. Prices of Custom Dies will vary, depending on the over-all size of the imprint area and whether typesetting is required. (See Custom Dies" Information Sheet)

Special Attachments Or Fixtures

Occasionally you may have a need to imprint an odd shaped item. Don't turn away that job. We can usually manufacture a special fixture that will enable you to imprint your product. The usual time for production of these fixtures will be two weeks.

Rollfeed Installation (New)

To properly install the Automatic ROLLFEED to you machine, remove the two hex nuts that hold the "insulation block" on the Rollfeed, these are just for shipping purposes only. Have your allen wrench ready to insert in the allen screws used for attaching the Rollfeed to the aluminum yoke assembly just above the Typeholder. **First make sure the "Foil Spool" is on the Left and the "Rollers" are on the right.** Pull the handle of the machine down to lower the Typeholder to the platform and hold it down. Then place the center of the Rollfeed with the Insulation Block and Screws up against the aluminum yoke assembly above the Typeholder. Using the allen wrench provided, tighten the screws into the pre-drilled and taped holder located on the back of the aluminum yoke assembly. Prior to the final tightening, Level the Rollfeed with the Typeholder by eye or the platform by touching the "Rollfeed Feet" and rubber guides to the edge of the platform. Finally, tighten the screws with the allen wrench and return the handle to the upright position. See the next section for the adjusting the advancement of the foil on the Rollfeed.

Rollfeed Adjustment

See instructions for the "Adjustment of the Rollfeed". There are two adjustments to be made for the foil advancement and pull length of the foil.

First, adjust the rubber foil guides to the width of the foil being used, allowing little or no play from side to side. Next, adjust the pull length of the foil by holding the Typeholder in the down position, while adjusting the "Knurled Bushing" on the ratchet rack, which is located in the rollfeed housing. Finally turn the "Knurled Bushing counter-clockwise to lengthen the pull of foil. (Note: the number of turns will not represent the number of inches)

The rollfeed is shipped from the factory with the minimum amount of pull length and should be adjusted prior to use. It has to be adjusted according to the length of line to be stamped to insure the minimum amount of foil waste.

Care Of The Machine

All parts of the "KWIKPRINT" machine are precision made in our factory. Some of our machines are still in operation after 60 years of service. There are only a few parts that eventually need replacing.

The heat unit, being an electrical component, will need periodic replacement. We suggest that an extra element be kept on hand so production will not be interrupted.

Typeholder lubrication is needed periodically, due to the constant heating and cooling of the metals. A coat of "Heat- Resistant" grease on all moving parts of the Typeholder will insure free-movement of the jaws.

The tilt lock handle, that locks the Typeholder in the up position will wear after normal use. This part can be replaced by loosening the screw that holds it in place on the yoke assembly. If the Typeholder becomes loose after it is locked in place, you should replace the tilt lock handle, in order to keep the Typeholder secured while stamping.

The rollfeed chain should be greased periodically to keep it from binding and hard to advance. The rollfeed chain may also become loose with normal use. Usually removing a link or two will solve the problem. It does become necessary to replace the chain after a extended usage.

Adjusting The Platform

All machines are tested and aligned prior to shipment from the factory. The Typeholder and platform are aligned together and should not have to be adjusted when you receive the machine. However, during shipping the machine may be mishandled, so you may have to adjust the platform slightly to insure quality stamping. If the platform is not aligned it may cause "uneven" stamping. To test your alignment, use two sheets of paper.

If adjusting is necessary, you will need to determine where the adjustment should be made. Which side and/or front or back. You should align the platform as if it were divided into 4-parts: left-front, left-rear, right-front, right-rear and adjust accordingly. If the left side is too light on the imprint, then you will need to raise that side to bring it even with the right. By using the adjusting nuts below the platform, loosen the bottom nut a half turn, then turn the middle nut clockwise 1/4 turn to raise that side of the platform.

Test your imprint again and see if it is correct. You should remember to tighten the bottom nut after you have completed the alignment. If you need additional assistance on this adjustment, please contact our service department. **DO NOT USE A "BUBBLE LEVEL" TO ADJUST YOUR PLATFORM.**

Replacing The Heat Unit

Tilt your Typeholder in the up position and lock the tilt-lock in place. Using a Slot" screw driver, loosen the 3 screws on the bottom of the Typeholder that holds the aluminum cover plate on, (you need not remove the screws), then holding the lead wire of the heat unit pull the heat unit out from the left-side. If the element is still HOT place it down on something that will not melt.

Holding the NEW heat unit with your left hand, with the smooth surface of the heat unit up and the "fold-side" down, slide the heat unit in the Typeholder, just as you removed it. Tighten the 3 screws that holds the cover plate on securely.

Make sure the heat unit is held tight. It should not move, once the screws are tightened. A loose heat unit will shorten its life-span and will not heat effectively.

Warranty: 1 Year, Parts And Labor

We would ask that you complete the information and warranty card you received with your machine. This will allow us to register your equipment for warranty purposes, and track the attachments received with the machine.

It is important, when ordering replacement parts, to know your Model Number and Serial Number of the machine. This helps to insure that you receive the correct parts and avoids a delay in shipping

The Owners and Employees of KWIKPRINT thank you for choosing our company and its products. Our mission is to continually improve the manufacturing of quality products at a competitive cost. Let us know if we are serving your needs.

Sincerely,

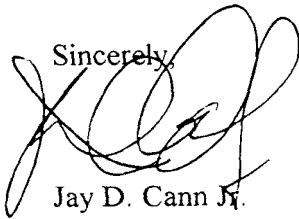
A handwritten signature in black ink, appearing to read "Jay D. Cann Jr.", written over the word "Sincerely,".

Jay D. Cann Jr.
President

ADJUSTING THE PLATFORM

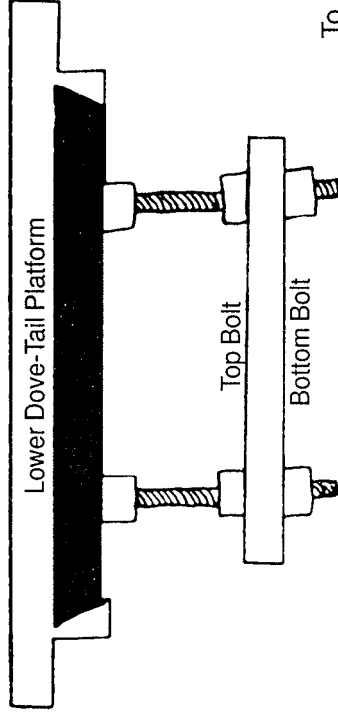
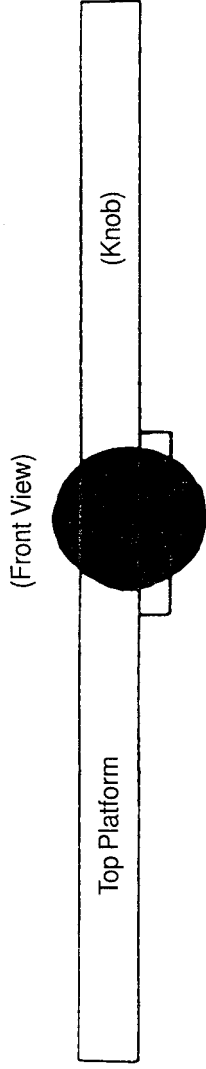

To bring a side of the platform up, place a wrench on the bottom bolt and turn the bottom bolt to the left (Clockwise), about a half turn. Then, tighten the **Top Bolt** by turning to the left (Clockwise).

Above steps may need to be repeated to achieve an even stamp.

To bring a side of the platform down, place a wrench on the **Top Bolt** and turn the **Top Bolt** to the right (Counter-Clockwise) about a half turn. Then, tighten the **Bottom Bolt** by turning to the right (Counter-Clockwise).

Above steps may need to be repeated to achieve an even stamp.

...Do not use a bubble level...

“PRINCIPLES OF HOT STAMPING FOIL”

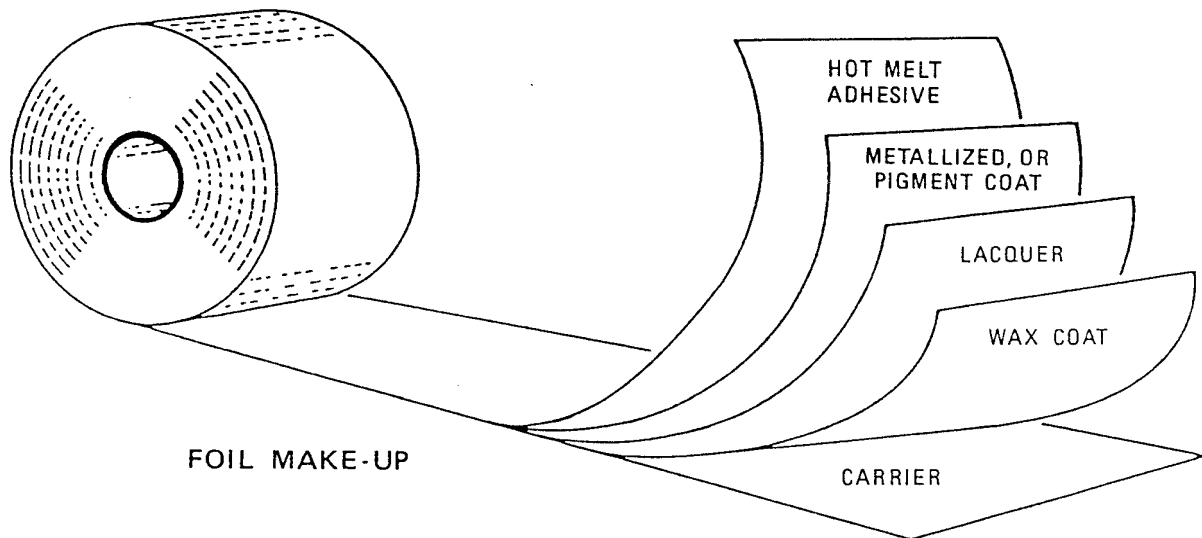

Hot stamping foil, roll-leaf, or tape, as it is often referred to, is comprised of a carrier film and various heat reactive coatings. An image or design is transferred from the foil by the application of pressure and heat to the carrier material for a brief duration (referred to as dwell) normally less than a second; temperature is determined by the foil composition and the material it is being applied to.

The image is determined and pressure applied via a die, engraved in metal or molded of silicone rubber. Metal dies, while having the ability to deboss an imprint below the surface, also require relatively high pressure. Rubber dies, being of a flexible nature, require less pressure and have the ability to conform to surface irregularities.

Roll leaf foils are produced in a variety of pigment, metallic, woodgrain colors and multi-color transfers. The carrier onto which the finishes are deposited is usually a polyester or cellophane. The first coating on the carrier is the release coat, a material that will release clean in the exact area heated to a specific temperature by the metal or rubber die. The second and third coatings are comprised of various lacquer/pigment mixtures and/or vacuum metallized materials. The final coat is the heat sensitive adhesive activating a secure bond to the material being decorated.

The combination of heat and pressure of the hot stamping operation fuse these layers and the substrate into homogeneous systems. Foils produced in roll form are wound into 24" wide master rolls x 200', 400' and 1000' lengths.

FEATURES OF ROLL LEAF (Hot Stamp) FOILS:

- * The process is completely dry and requires no cleanup.
- * Being a dry process, the finished items can be handled immediately.
- * Roll leaf decorating is environmentally clean.
- * Foil pattern changes require a simple substitution of the foil roll and rethreading through the machine.
- * Roll leaf foils are available for a wide variety of application in which they have resistance to solvents, acids, alcohols, exposure, handling and abrasion.

Rollfeed Parts List for Kwikprint Models
719, 819, 319

- 1. (RF-103) HOUSING ONLY
- 2. (RF-134) RACK W/TB
- 4. (RF-126) KNURLED BUSHING
- 5. (RF-106) RACK SPRING
- 6. (RF-135) 24T/48T GEAR SET
- 7. (RF-104) CHAIN
- 8. (RF-116) 24T SPROCKET
- 9. (RF-109) PAWL
- 10. (RF-108) PAWL SPRING
- 11. (RF-105) ROLLER SPRING
- 12. (RF-107) SPOOL SPRING
- 13. (RF-122/1) 1" RF FEET W/GUIDES
- (RF-122/2) 2" RF FEET W/GUIDES
- (RF-122/3) 3" RF FEET W/GUIDES
- 14. (RF-115) FOIL GUIDES
- 15. (RF-146) SPOOL WASHER

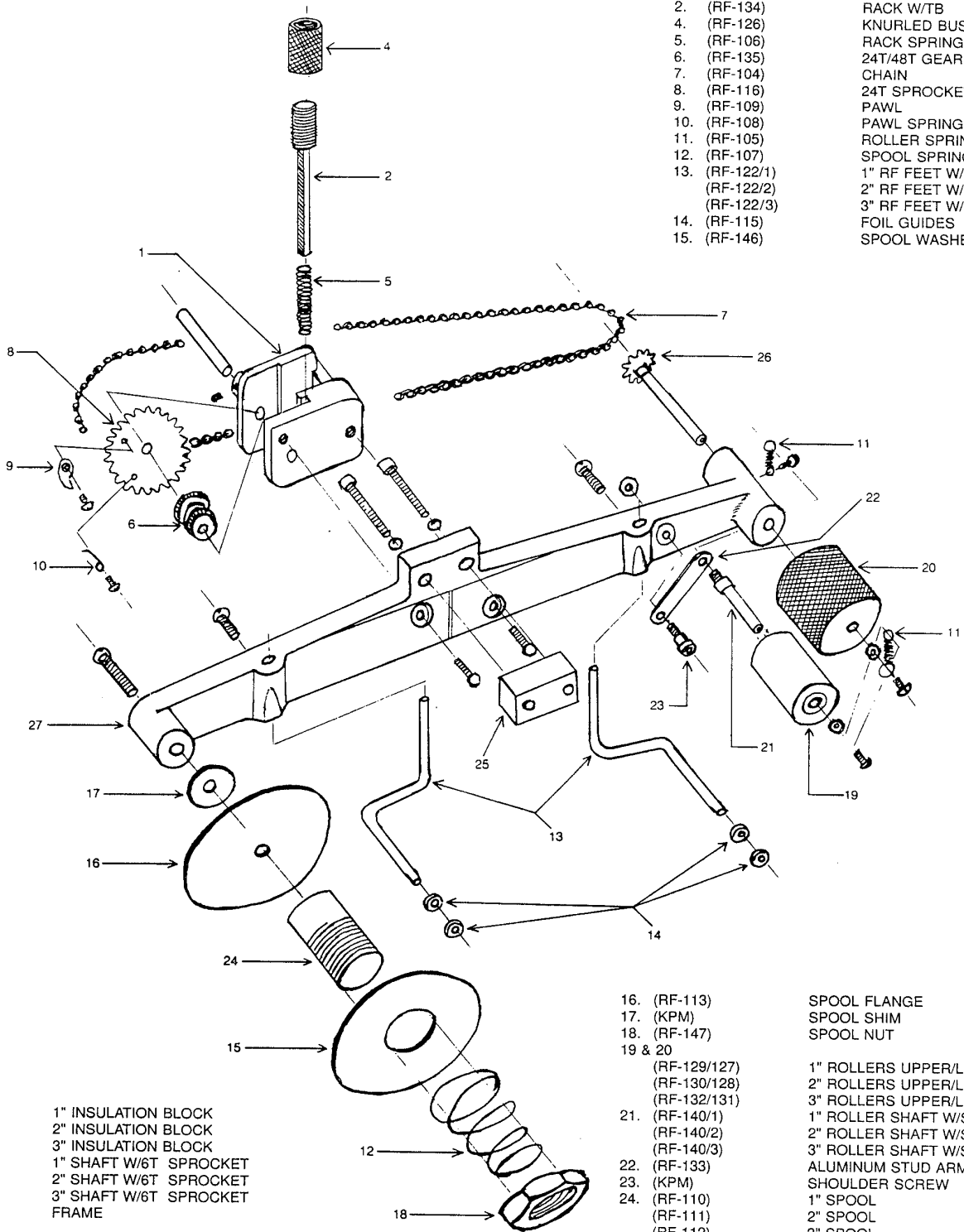

- 25. (RF-123/1) 1" INSULATION BLOCK
- (RF-123/2) 2" INSULATION BLOCK
- (RF-123/3) 3" INSULATION BLOCK
- 26. (RF-118/1) 1" SHAFT W/6T SPROCKET
- (RF-118/2) 2" SHAFT W/6T SPROCKET
- (RF-118/3) 3" SHAFT W/6T SPROCKET
- 27. (RF-101) FRAME

- 16. (RF-113) SPOOL FLANGE
- 17. (KPM) SPOOL SHIM
- 18. (RF-147) SPOOL NUT
- 19 & 20 (RF-129/127) 1" ROLLERS UPPER/LOWER
- (RF-130/128) 2" ROLLERS UPPER/LOWER
- (RF-132/131) 3" ROLLERS UPPER/LOWER
- 21. (RF-140/1) 1" ROLLER SHAFT W/STUD ARM
- (RF-140/2) 2" ROLLER SHAFT W/STUD ARM
- (RF-140/3) 3" ROLLER SHAFT W/STUD ARM
- 22. (RF-133) ALUMINUM STUD ARM
- 23. (KPM) SHOULDER SCREW
- 24. (RF-110) 1" SPOOL
- (RF-111) 2" SPOOL
- (RF-112) 3" SPOOL

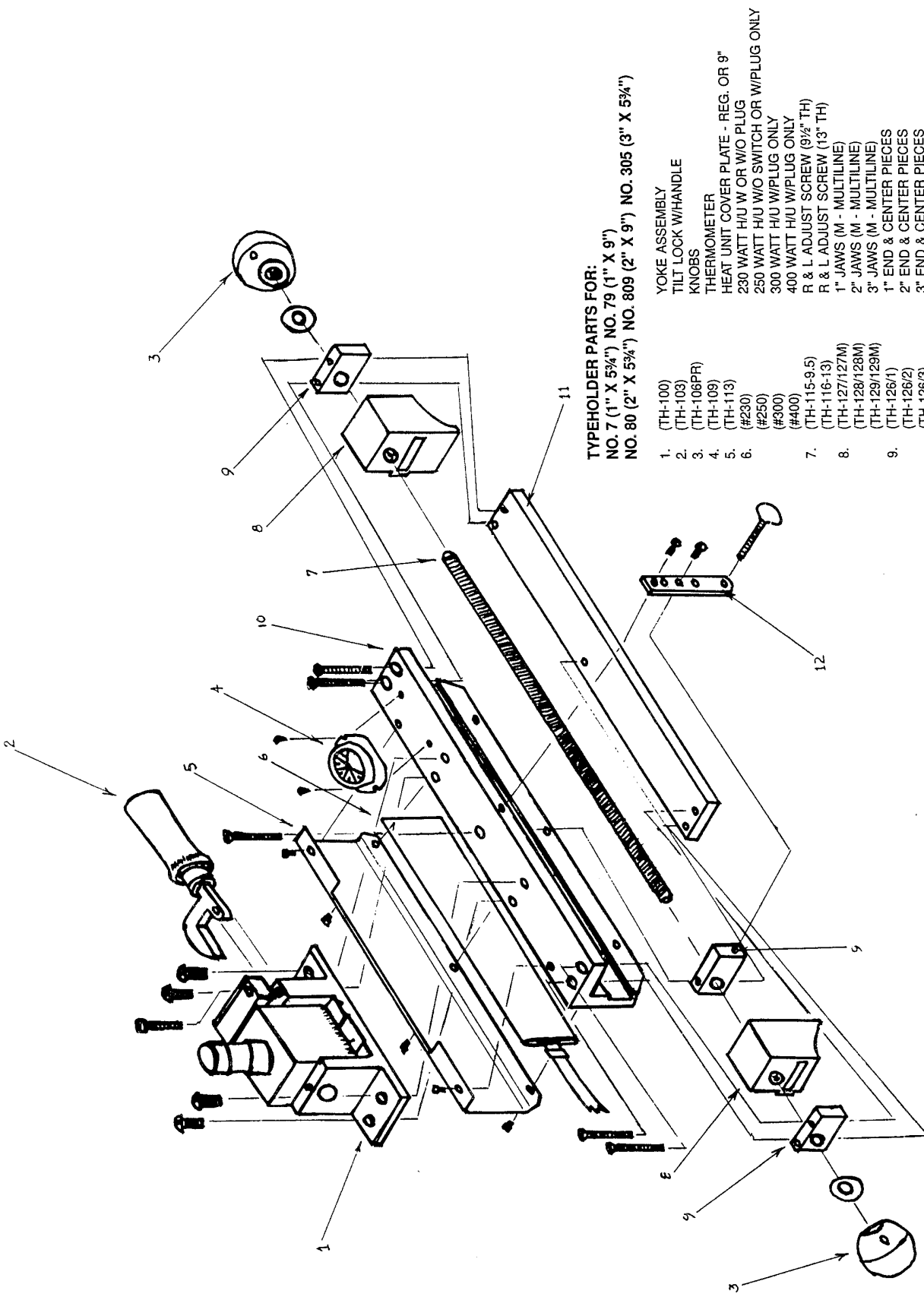

- TYPEHOLDER PARTS FOR:**
NO. 7 (1" X 5 1/4") NO. 79 (1" X 9")
NO. 80 (2" X 5 1/4") NO. 809 (2" X 9") NO. 305 (3" X 5 1/4")
- | | | |
|-----|---------------|----------------------------------------|
| 1. | (TH-100) | YOKE ASSEMBLY |
| 2. | (TH-103) | TILT LOCK W/HANDLE |
| 3. | (TH-106PR) | KNOB |
| 4. | (TH-109) | THERMOMETER |
| 5. | (TH-113) | HEAT UNIT COVER PLATE - REG. OR 9" |
| 6. | (#230) | 230 WATT H/U W/O PLUG |
| | (#250) | 250 WATT H/U W/O SWITCH OR W/PLUG ONLY |
| | (#300) | 300 WATT H/U W/PLUG ONLY |
| | (#400) | 400 WATT H/U W/PLUG ONLY |
| 7. | (TH-115-9.5) | R & L ADJUST SCREW (9 1/2" TH) |
| | (TH-116-13) | R & L ADJUST SCREW (13" TH) |
| 8. | (TH-127/127M) | 1" JAWS (M - MULTILINE) |
| | (TH-128/128M) | 2" JAWS (M - MULTILINE) |
| | (TH-129/129M) | 3" JAWS (M - MULTILINE) |
| 9. | (TH-126/1) | 1" END & CENTER PIECES |
| | (TH-126/2) | 2" END & CENTER PIECES |
| | (TH-126/3) | 3" END & CENTER PIECES |
| 10. | (TH-121/1) | 1" TH BODY |
| | (TH-121/2) | 2" TH BODY |
| | (TH-121/3) | 3" TH BODY |
| | (TH-122/1) | 1" x 9" BODY |
| | (TH-122/2) | 2" x 9" BODY |
| 11. | (TH-117/1) | 1" GUIDE BAR |
| | (TH-117/2) | 2" GUIDE BAR |
| | (TH-117/3) | 3" GUIDE BAR |
| | (TH-118/1) | 1" x 9" GUIDE BAR |
| | (TH-118/2) | 2" x 9" GUIDE BAR |
| 12. | (TH-110) | TYPE SUPPORT |

TABLE OF PULLS

This table tells you the number of impressions that can be made from any standard length roll based on length of pull. Determine the pull by measuring across the impression or die in the direction the foil is to travel. Be sure to add at least 1/8 inch to the actual measurement.

Jumbo rolls in lengths of 3000, 4000 and 5000 ft., wound on 3 inch cores are available from Swift for special application. Write for details.

FROM STANDARD LENGTH ROLLS

Pull Length	*100' Roll	200' Roll	400' Roll	600' Roll	1000' Roll	2000' Roll	Pull Length	*100' Roll	200' Roll	400' Roll	600' Roll	1000' Roll	2000' Roll
3/16"	6400	12800	25600	38400	64000	128000	3 3/4"	320	640	1280	1920	3200	6400
5/16"	3840	7680	15360	23040	38400	76800	3 7/8"	309	618	1236	1854	3090	6180
3/8"	2742	5484	10968	16452	27420	54840	4"	300	600	1200	1800	3000	6000
5/8"	2133	4266	8532	12798	21330	42660	4 1/8"	290	581	1160	1740	2900	5810
1 1/16"	1745	3490	6980	10470	17450	34900	4 1/4"	282	564	1128	1692	2820	5640
1 3/16"	1477	2954	5908	8862	14770	29540	4 3/8"	274	548	1096	1644	2740	5480
1 5/16"	1280	2560	5120	7680	12800	25600	4 1/2"	267	533	1068	1602	2670	5330
1/8"	9600	19200	38400	57600	96000	192000	4 5/8"	259	518	1036	1554	2590	5180
3/8"	3200	6400	12800	19200	32000	64000	4 3/4"	252	505	1008	1512	2520	5050
5/8"	1920	3840	7680	11520	19200	38400	4 7/8"	246	492	984	1476	2460	4920
7/8"	1370	2740	5480	8220	13700	27400	5"	240	480	960	1440	2400	4800
1/4"	4800	9600	19200	28800	48000	96000	5 1/8"	234	468	936	1404	2340	4680
3/4"	1600	3200	6400	9600	16000	32000	5 1/4"	229	457	916	1374	2290	4570
1/2"	2400	4800	9600	14400	24000	48000	5 3/8"	223	446	892	1338	2230	4460
1"	1200	2400	4800	7200	12000	24000	5 1/2"	218	436	872	1308	2180	4360
1 1/8"	1066	2132	4264	6396	10660	21320	5 5/8"	213	426	852	1278	2130	4260
1 1/4"	960	1920	3840	5760	9600	19200	5 3/4"	208	416	832	1248	2080	4160
1 3/8"	872	1744	3488	5232	8720	17440	5 7/8"	204	408	816	1224	2040	4080
1 1/2"	800	1600	3200	4800	8000	16000	6"	200	400	800	1200	2000	4000
1 5/8"	738	1476	2952	4428	7380	14760	6 1/8"	195	390	780	1170	1950	3900
1 3/4"	685	1370	2740	4110	6850	13700	6 1/4"	192	384	768	1152	1920	3840
1 7/8"	640	1280	2560	3840	6400	12800	6 3/8"	188	376	752	1128	1880	3760
2"	600	1200	2400	3600	6000	12000	6 1/2"	187	369	748	1122	1870	3690
2 1/8"	564	1128	2256	3384	5640	11280	6 5/8"	181	362	724	1086	1810	3620
2 1/4"	533	1066	2132	3198	5330	10660	6 3/4"	177	355	708	1062	1770	3550
2 3/8"	505	1010	2020	3030	5050	10100	6 7/8"	174	349	696	1044	1740	3490
2 1/2"	480	960	1920	2880	4800	9600	7"	171	342	684	1026	1710	3420
2 5/8"	457	914	1828	2742	4570	9140	7 1/8"	168	336	672	1008	1680	3360
2 3/4"	436	872	1744	2616	4360	8720	7 1/4"	165	331	660	990	1650	3310
2 7/8"	417	834	1668	2502	4170	8340	7 3/8"	162	324	648	972	1620	3240
3"	400	800	1600	2400	4000	8000	7 1/2"	160	320	640	960	1600	3200
3 1/8"	384	768	1536	2304	3840	7680	7 5/8"	157	314	628	942	1570	3140
3 1/4"	369	738	1476	2214	3690	7380	7 3/4"	154	309	616	924	1540	3090
3 3/8"	355	710	1420	2130	3550	7100	7 7/8"	152	304	608	912	1520	3040
3 1/2"	342	684	1368	2052	3420	6840	8"	150	300	600	900	1500	3000
3 5/8"	331	662	1324	1986	3310	6620							

*Available only in Genuine Gold.

KWIKPRINT PARTS LIST

OCTOBER 1, 1988

STANDARD PARTS - ALL MODELS

POWER LEVER WITH HANDLE -----	5.00
RAM CAP -----	2.30
FACE PLATE -----	4.25
STEEL RAM -----	38.80
STEEL PINION -----	20.60
RAM SPRING -----	4.15
LINEBOARD -----	15.75
LOWER DOVETAIL PLATFORM -----	30.00
TOP PLATFORM -----	146.00

MODEL 55

MODEL 55 FRAME (COMPLETE WITH RAM & PINION) -----	478.00
---------------------------------------------------	--------

MODEL 86 & 64

HEAD CASTING (COMPLETE WITH RAM & PINION) -----	246.00
LOWER BRACKET (MODEL 86 ONLY) -----	130.00
COLUMN CAP -----	11.60
STEEL COLUMN -----	56.00
RAISE & LOWER SCREW -----	17.00
LOCK HANDLES -----	22.00/PR.
CRANK HANDLE -----	15.70
BASE -----	136.00

TYPEHOLDERS

130 WATT HEAT UNIT (115V OR 220V) W/O SWITCH -----	34.00
230 WATT HEAT UNIT (115V OR 220V) W/O SWITCH -----	38.00
250 WATT HEAT UNIT (SPECIAL - 115V ONLY) W/O SWITCH -----	39.00
300 WATT HEAT UNIT (115V OR 220V) -----	40.00
BRASS TILT LOCK WITH WOOD HANDLE -----	7.50
COMPLETE YOKE HOUSING -----	70.00
JAWS 1" PER SET -----	34.00
JAWS 1" MULTILINE PER SET -----	49.00
JAWS 2" PER SET -----	50.00
JAWS 2" MULTILINE PER SET -----	65.00
KNOBS -----	12.00/PR.
STEEL GUIDE BAR 1" -----	12.00
STEEL GUIDE BAR 2" -----	24.00
HEAT UNIT COVER PLATE -----	4.00
RIGHT & LEFT ADJUST SCREW (9½" OR 13") -----	11.50
THREE POSITION SWITCH -----	10.00
THERMOMETER -----	7.50
TYPE SUPPORT WITH SCREWS -----	4.00
END & CENTER PIECES (1" OR 2") -----	10.00/SET

MINIMUM CHARGE - \$10.00

ALL PRICES SUBJECT TO CHANGE WITHOUT NOTICE

AUTOMATIC ROLLFEED

ALUMINUM FRAME -----	42.00
ROLLFEED HOUSING ONLY -----	40.00
ROLLFEED HOUSING COMPLETE -----	135.00
SPOOL 1" -----	5.00
SPOOL 1" WITH NUT, WASHER & SPRING -----	8.00
SPOOL 2" -----	5.75
SPOOL 2" WITH NUT, WASHER & SPRING -----	8.75
ROLLERS 1" SET (UPPER 10.60, LOWER 11.40) -----	22.00
ROLLERS 2" SET (UPPER 12.60, LOWER 14.40) -----	27.00
KNURLED BUSHING -----	5.00
STEEL RACK WITH THREADED BUSHING -----	13.00
24 TOOTH BRASS SPROCKET GEAR -----	25.00
24 TOOTH/48 TOOTH STEEL GEAR SET -----	28.00
ROLLFEED CHAIN (FOR 5-3/4" OR 9" ROLLFEED) -----	3.00
RATCHET SPRING -----	2.00
ROLLER SPRING -----	2.75
SPOOL SPRING -----	2.00
PAWL SPRING -----	4.00
STEEL PAWL -----	6.50
STEEL SPROCKET SHAFT WITH GEAR (6T OR 9T) -----	16.00
INSULATION BLOCK 1" -----	4.00
INSULATION BLOCK 2" -----	4.25
RUBBER FOIL GUIDES -----	.25
RIGHT ANGLE FEET WITH GUIDES 1" -----	6.00/SET
RIGHT ANGLE FEET WITH GUIDES 2" -----	6.15/SET
THREADED STUD (FOR ROLLERS) -----	4.00

ACCESSORIES

STEEL LUGGAGE BLOCK FOR MODEL 64 -----	7.00
LUGGAGE GAUGE FOR MODEL 64 -----	15.00
ALUMINUM TYPE STICK -----	1.00
ALUMINUM WORKHOLDERS -----	2.00/PR.

AIR OPERATED MODEL 86

CYLINDER -----	180.77
VALVE 180001 -----	40.50
VALVE 180003 -----	46.41
TIMER (.1 - 3 SEC) -----	150.00
EXHAUST RESTRICTOR -----	9.28
CFR55-2, FILTER/REGULATOR -----	32.03
70-MDD, PRESSURE GAUGE -----	9.00
L50-2, LUBRICATOR -----	27.90
AIR HEAD CASTING (COMPLETE WITH RAM & PINION) -----	245.19

KWIKPRINT PRICE LIST

SEPTEMBER 30, 1988

MACHINES* (w/o TYPEHOLDER)

MODEL 55	715.00
MODEL 86	825.00
MODEL 64	1150.00
NO. AA	AIR OPERATED KIT (MODEL 86 ONLY)	800.00**
NO. SC20100	HAND CONTROL (OSHA APPROVED)	(NET) 300.00**

**AUTOMATIC HEAT CONTROL INCLUDED AS STANDARD EQUIPMENT*

TYPEHOLDERS

NO. 7	1" x 5 $\frac{3}{4}$ " TYPEHOLDER	225.00
NO. 83	1" x 5 $\frac{3}{4}$ " MULTILINE TYPEHOLDER	240.00
NO. 79	1" x 9" TYPEHOLDER	250.00
NO. 79M	1" x 9" MULTILINE TYPEHOLDER	265.00
NO. 80	2" x 5 $\frac{3}{4}$ " TYPEHOLDER	260.00
NO. 83A	2" x 5 $\frac{3}{4}$ " MULTILINE TYPEHOLDER	275.00
NO. 809	2" x 9" TYPEHOLDER	325.00
NO. 809M	2" x 9" MULTILINE TYPEHOLDER	340.00

ADD: \$10.00 FOR TYPEHOLDERS REQUIRING SWITCH AND CORD

ROLLFEEDS

NO. 719	1" x 9" AUTOMATIC ROLLFEED	200.00
NO. 819	2" x 9" AUTOMATIC ROLLFEED	220.00

ATTACHMENTS

NO. GO-495-160	AIR OPERATED COUNTER	120.00
NO. 50	PRECISION LINEFINDER	50.00
NO. 820	AUTOMATIC HEAT CONTROL	60.00
NO. 52	TWO-WAY ADJUSTABLE PLATFORM (PURCHASED ON MACHINE \$50.00)	140.00
NO. 116	MACHINE LIGHT	40.00
NO. 10	RIGHT ANGLE PLATFORM GAUGES	35.00
NO. 46	PENCIL ATTACHMENT	60.00
NO. 47	MATCH ATTACHMENT	60.00
NO. 49	PLAYING CARD ATTACHMENT	60.00
NO. 54-01-01	AIR FOOT VALVE w/ GUARD	70.00

***AIR OPERATED MODEL 86 IS AVAILABLE ONLY WITH THE OSHA APPROVED HAND CONTROLS.*

REPLACEMENT HEAT UNITS

**#27 — W/SWITCH OR #27A — W/O SWITCH*

1" x 5 $\frac{3}{4}$ " TYPEHOLDER	130 WATT	#27 — \$44.00/#27A — \$34.00
2" x 5 $\frac{3}{4}$ " TYPEHOLDER	230 WATT	#27 — \$48.00/#27A — \$38.00
1" x 9" TYPEHOLDER	230 WATT	#27 — \$48.00/#27A — \$38.00
2" x 9" TYPEHOLDER	300 WATT	#27 — \$50.00/#27A — \$40.00

**SPECIAL HIGH-HEAT UNIT AVAILABLE 250 WATT, FOR HEAT CONTROL ONLY*

SUPPLIES

F41602/F41601	GENUINE GOLD FOIL, ROLLS FROM 1" WIDE x 200'	PRICE BY REQUEST
B SERIES	IMITATION GOLD AND SILVER FOIL, PER 1" x 200'	2.00
C SERIES/ G SERIES/ V SERIES	COLORS, 1" x 200'	2.00
AF-428	IMITATION GOLD MYLAR, PER 1" x 200'	2.00

ALL PRICES FOB JACKSONVILLE, FL AND SUBJECT TO CHANGE

MINIMUM CHARGE \$10.00

WE ALSO CARRY A COMPLETE LINE OF SERVICE TYPE

BCGV

AF-428

KWIKPRINT STOCK FOILS

IMITATION GOLDS AND SILVERS

B41001	GOLD, PALE COLOR	ALL PURPOSE
B41210	SILVER, PALE COLOR	ALL PURPOSE
G41601	GOLD, HI-LUSTER	ALL PURPOSE
G41202	SILVER, HI-LUSTER	ALL PURPOSE
G/Silver	IMIT. SILVER	ALL PURPOSE
AF-428	GOLD, MEDIUM LUSTER	ALL PURPOSE
G41685	GOLD, HI-LUSTER	ESPECIALLY FOR RIBBONS
G41657	GOLD, MEDIUM LUSTER	FOR LEATHER & ALL PURPOSE
G-220	GOLD, HI-LUSTER	ALL PURPOSE

GLITTERFOILS

BH 6506	PINK, HI-LUSTER	ALL PURPOSE
G42401	COPPER, HI-LUSTER	ALL PURPOSE
LT-390	GREEN, HI-LUSTER	ALL PURPOSE
LT-391	BLUE, HI-LUSTER	ALL PURPOSE
LT-392	RED, HI-LUSTER	ALL PURPOSE

PIGMENT COLORS

C40116	BLACK, MATTE FINISH	ALL PURPOSE
C40117	BLACK, HI-GLOSS	FOR PLASTICS
V-912	BLACK, SEMI-GLOSS	ALL PURPOSE
LT-362	BLACK, GLOSS	PAPER PRODUCTS
V-914	BEIGE, SEMI-GLOSS	PAPER PRODUCTS
C40311	RED, SEMI-GLOSS	COATED PAPER/PLASTICS
C40307	RED, HI-GLOSS	FINE LINE/PLASTICS
V-904	RED, SEMI-GLOSS	PAPER PRODUCTS
V-954	RED, SEMI-GLOSS	ALL PURPOSE
C40234	WHITE, MATTE FINISH	ALL PURPOSE
C40208	WHITE, MATTE FINISH	FOR PLASTICS
C40201	WHITE, SEMI-GLOSS	FOR PLASTICS
V-911	WHITE, SEMI-GLOSS	ALL PURPOSE
V-915	YELLOW, SEMI-GLOSS	ALL PURPOSE
V-921	MAROON, SEMI-GLOSS	ALL PURPOSE
V-907	ORANGE, SEMI-GLOSS	ALL PURPOSE
C40606	GREEN, MATTE FINISH	ALL PURPOSE
V-939	GREEN, SEMI-GLOSS	ALL PURPOSE
V-920	GREEN, SEMI-GLOSS	ALL PURPOSE
C40706	BLUE, MATTE FINISH	ALL PURPOSE
V-935	LT. BLUE, SEMI-GLOSS	COATED PAPER/PLASTIC
C40717	BLUE, HI-GLOSS	COATED PAPER/PLASTIC
V-917	DK. BLUE, SEMI-GLOSS	PAPER PRODUCTS
V-901	BLUE, SEMI-GLOSS	ALL PURPOSE
V-941	PINK, SEMI-GLOSS	ALL PURPOSE
C20902	BROWN, MATTE FINISH	ALL PURPOSE
C40907	BROWN, SEMI-GLOSS	FOR PLASTICS
V-938	BROWN, SEMI-GLOSS	IMIT. LEATHER, IMIT. SUEDES & ALL PURPOSE

GENUINE GOLD

F41601	22K GOLD FOIL, HI-LUSTER; USE ON LEATHER, PAPER, ACETATE, VINYL, POLYSTYRENE, BOOKCLOTH, PROXYLIN.
F41602	22K GOLD FOIL, MEDIUM LUSTER; USE ON THE SAME AS ABOVE.

We have had many KWIKPRINT users that have contacted us with problems of unsatisfactory impressions and stampings. In about 90% of the cases it has been a question of not having the correct foil for the material being stamped. In the other 10% it has been either a heat unit that is burning out or a poor base or markeready on which they are stamping.

Plastics are the main offenders and there are many cases where the same foil will not transfer to a plastic that appears to be the same as being stamped previously. We again suggest that problems of this nature be referred to us for experiment.

ASK FOR SAMPLE. A letter or card from you indicating that you would like samples of our foil will be given immediate attention—no obligation on your part. OUR ONE PURPOSE IS TO PROPERLY AND EFFECTIVELY RENDER SERVICE TO OUR CUSTOMERS. KWIKPRINT SERVICE AND NAME AS STAMPING HEADQUARTERS is your guarantee of complete satisfaction.

PLASTIC STAMPING. We suggest that you submit samples of your plastic and we will gladly recommend the proper foil.

VERSATILITY. The versatility of KWIKPRINT is amazing. It stamps with equal ease hard plastics as used in desk plates, small advertising calendars, samples of floor and wall tile, trademarking, etc.